



# POMPA PER VUOTO LUBRIFICATA AD INIEZIONE D'OLIO OIL INJECTION LUBRICATED VACUUM PUMP

## 100 PBO - PBOM



Gruppo pompante, in ghisa, accoppiato al motore tramite giunto a denti e ventola centrifuga per il raffreddamento. Serbatoio olio, con filtro, in alluminio con scomparto separazione e recupero aria/olio per l'eliminazione di nebbie d'olio in mandata. Valvola di ritegno in aspirazione. A necessità valvola zavorra gas e base d'appoggio.



Cast-iron pumping unit, coupled to the motor by means of a toothed joint and centrifugal fan for cooling. Oil tank, with filter, made of aluminium and with a compartment for separation and recovery of air/oil for eliminating oil mists on the delivery side. Check valve on the suction side. If required, gas ballast valve and supporting base.



### SPECIFICHE - SPECIFICATIONS

			50 Hz	60 Hz
Portata	Pumping speed	(Nm <sup>3</sup> /h)	100	120
Vuoto finale (Ass.)	Ult.vacuum (Abs)	(mbar)	10 PBO – 0,5 PBOM	10 PBO – 0,5 PBOM
Esecuzione motore	Motor version	(V) multi tensione – multivolts	Y 380-400-415-440-460-480	
			Δ 220-230-240-254-275	
		(V) 3 ~ - three phase	230/400	230/400
Potenza motore	Motor rating	(Kw) multi tensione – multivolts	3	3
		(Kw) 3 ~ - three phase	2.2	
Nr.giri	Motor speed	giri/min - rpm	1450	1740
Rumorosità media	Noise level	(dB)	73	73
Peso max.	Max.weight	(Kg)	87	87
Quantità olio	Oil capacity	(Lt.)	5.8	5.8

Salvo modifiche tecniche - We reserve the right to alter technical information.

### BGS GENERAL S.r.l.

Via ZIBIDO, 3 - 20080 ZIBIDO SAN GIACOMO Mi Italia - Tel. +39.02.90.00.50.69 r.a. - Fax. +39.02.90.00.57.75

E-mail : [bigiesse@bigiesse.it](mailto:bigiesse@bigiesse.it) - Internet: <http://www.bigiesse.it>

## DIMENSIONI - DIMENSIONS

(mm)	
A	705
B	360
C	440
D	278
E	117
F	118
G	230
H	340
K	258
L	160
M	445
N	115
O	115
P	160
R	44
Øa	1"1/4G
Øm	1"1/4G
Øf	10
X	231
Y	472
W	30

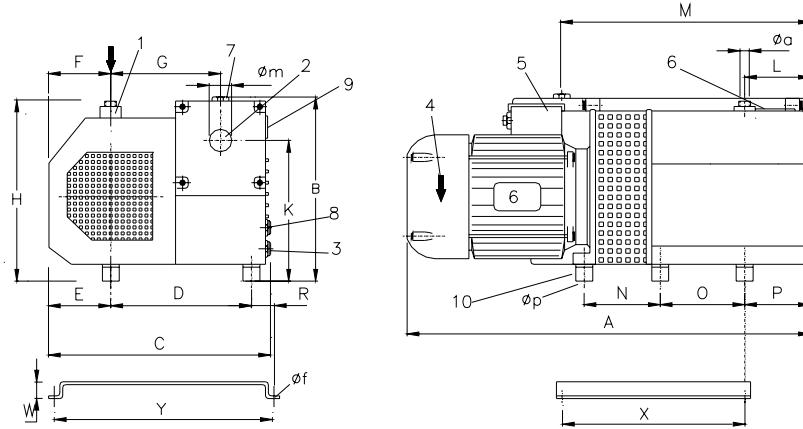

Salvo modifiche tecniche - We reserve the right to alter technical information.

1	Valvola di aspirazione	Suction valve	6	Targhetta dati	Data plate
2	Scarico aria	Exhaust	7	Tappo riempimento olio	Oil filler
3	Scarico olio	Oil drain	8	Spia livello olio	Oil control
4	Freccia senso di marcia	Rotation arrow	9	Targhetta oli consigliati	Oil type plate
5	Morsetti	Wiring box	10	Piedini	Damper

## PRESTAZIONI - PERFORMANCE CURVE

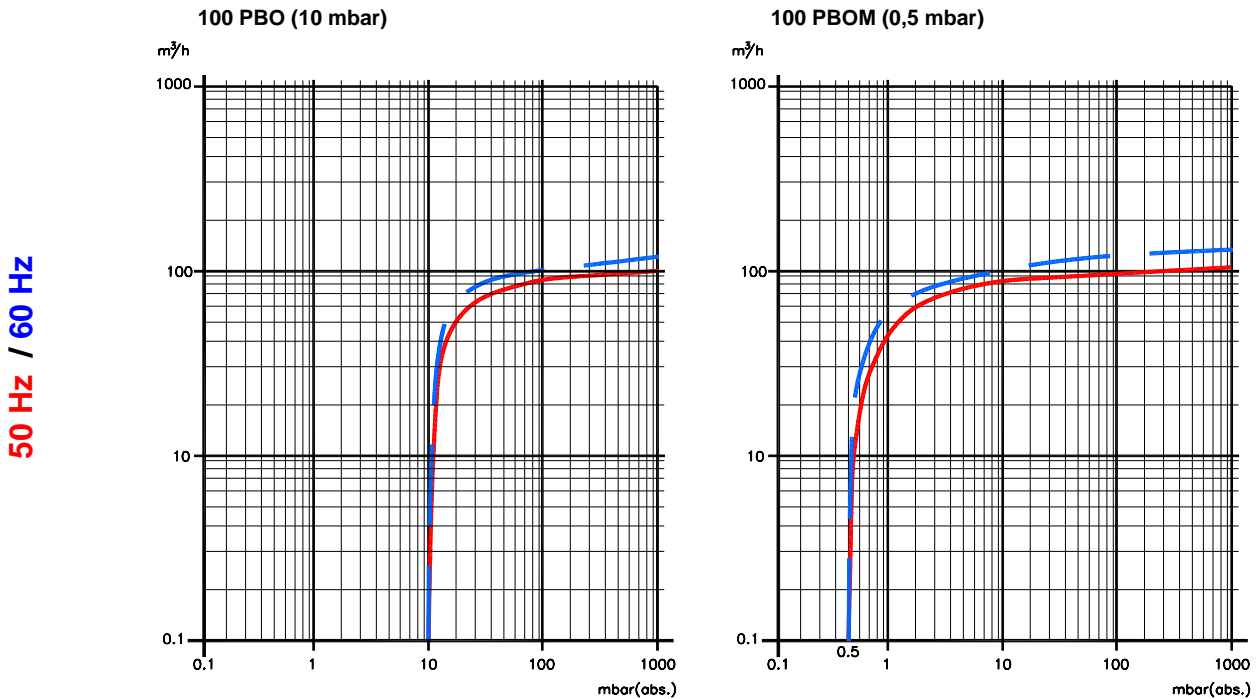

**BGS GENERAL S.r.l.**

Via ZIBIDO, 3 - 20080 ZIBIDO SAN GIACOMO Mi Italia - Tel. +39.02.90.00.50.69 r.a. - Fax. +39.02.90.00.57.75

E-mail : [biges@biges.it](mailto:biges@biges.it) - Internet: <http://www.biges.it>